

S205

Turbo

Skid-Steer Loader



One Tough Animal™

Bobcat® S205 Turbo Skid-Steer Loader

Specifications

Performance

Rated Operating Capacity¹
ROC with Optional Counterweight
Tipping Load
Hydraulic Pump Capacity
High Flow Option
Travel Speed
Operating Weight

S205

2050 lb. (930 kg)
2150 lb. (977 kg)
4100 lb. (1864 kg)
16.3 GPM (62 L/min.)
25.5 GPM (97 L/min.)
7.0 MPH (11.3 km/hr.)
6242 lb. (2831 kg)

Dimensions

Length (with bucket) 130.3 in. (3309 mm)
Width (with bucket) 68.0 in. (1727 mm)
Height 76.3 in. (1938 mm)
Height to Bucket Pin 118.2 in. (3002 mm)

Engine

Make/Model
Fuel/Cooling
Cylinders
SAE NET HP/Displacement
Fuel Tank Capacity

Kubota/V2403 M-DI-T
Diesel/Liquid
4
61/148.5 in.³
24 gal. (90.8 L)

Operation

Steering and Drive

Forward, reverse, travel speed and steering controlled by two hand levers.
Raise/lower lift arms and dump/rollback bucket controlled by two foot pedals or optional hand controls.
Hydrostatic, four-wheel drive.

Hydraulics

Transmission

Standard Features

Adjustable Cushion Seat
Automatically Activated Glow Plugs
Bobcat Interlock Control System (BICS™)
Bob-Tach
Deluxe Cab
Dual Path Cooling System
Engine/Hydraulic Shutdown
Front Auxiliary Hydraulics
Front & Rear Lights
Lift Arm Support
Gauges/Warning Lights
Operator Cab
Parking Brake
Seat Bar
Seat Belt
Tires: 31.5 x 13-16.5 Turbo-Charger (Approved Spark Arrestor)

Options/Accessories

Advanced Control System (ACS)
Air Conditioning
Alarm Package (backup alarm and horn)
Attachment Control Kit
Bobcat Heavy Duty Tires Heavy Duty Offset
Bobcat Poly-Fill Tires
Bobcat Severe Duty Tires
Cab Enclosure
Cab Heater
Catalytic Purifier
Counterweight
Deluxe Instrument Panel
Flasher/Strobe/Rotating Beacon Lights
Gold Option Package
High Flow Auxiliary Hydraulics Package
Hydraulic Bucket Positioning²
Keyless Start System
Power Bob-Tach
Radio Kit
Rear Auxiliary Hydraulics
Service Safety Training Kit
Side Windows
Silver Option Package
Skid-Steer Loader Operator Training Kit
Sound Cab
Special Applications Kit³
Suspension Seat (vinyl or cloth cover)

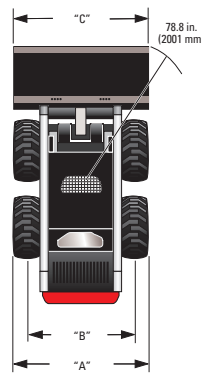
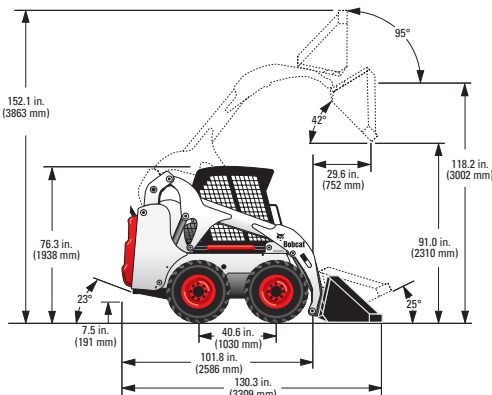

"A" 10 - 16.5 TIRES - 66.0" (1676 mm) or 60.0" (1524 mm)
31.5 x 13 - 16.5 TIRES - 66.0" (1676 mm)
"B" 10 - 16.5 TIRES - 56.4" (1433 mm) or 48.5" (1232 mm)
31.5 x 13 - 16.5 TIRES - 54.2" (1377 mm)
"C" 62 in. BUCKET WIDTH - 62.0" (1575 mm)
68 in. BUCKET WIDTH - 68.0" (1727 mm)
74 in. BUCKET WIDTH - 74.0" (1880 mm)

Bobcat S205 skid-steer loader... greater performance, visibility, comfort and value!

Greater Performance

Vertical-path lift arms deliver added performance on every jobsite:

- More lift capacity.
- More lift height and reach for truck loading.

Greater Visibility

The low-profile, vertical-path lift arm design and innovative cab enhance the operator's view to key areas during operation: the sides, front and rear corners of the loader.

Even with the optional front door, the S205 offers good visibility. As any operator will tell you, a better view of the work area means greater efficiency.

Greater Comfort

The cab is designed with the operator in mind, for optimum comfort and functionality. And with its larger opening and dual-tilt cylinder lift arm design, it's easy to enter and exit.

The seat bar pivots from the rear, providing secondary restraint protection; it's also a comfortable armrest for operators of all sizes. Plus, the worklight design doubles the amount of illumination to the work area for better operation in low-light areas.

Greater Options

- Factory- or field-installed, easy-to-read deluxe instrument panel.
- High-flow auxiliary hydraulics to operate attachments requiring high hydraulic horsepower, such as planers and stump grinders.
- Full suspension seat for all-day operator comfort.

Greater Value

Couple these features with proven power, smooth ride and vertical lift path capabilities and you've got a skid-steer loader that delivers top performance, no matter what the job. Get in the seat of a S205 today for a great view and an even greater value!

S205

2050 LB.
Rated Operating Capacity

118.2 IN.
Lift Height

61 HP

Turbo-Charged, Liquid-Cooled Diesel Engine

Optional Deluxe Instrument Package includes:

- Multi-language capability
- System diagnostic capability
- All gauges read in metric or English units
- Feature lockouts
- Keyless start security
- Digital and job clocks
- Help screens
- Attachment information

NOTE - Where applicable, dimensions are in accordance with Society of Automotive Engineers (SAE) and ISO standards. Specifications and design are subject to change without notice. Pictures of Bobcat loaders may show other than standard equipment. All dimensions are given for loader equipped with standard tires. All dimensions are shown in inches. Respective metric dimensions are enclosed by parentheses. Bobcat Company complies with the requirements of ISO 9001 as registered with BSI.

¹ Operating capacity rated with standard digging bucket according to SAE standard J818 - OPERATING CAPACITY TO EQUAL NO MORE THAN ONE HALF THE TIP LOAD.

² Bucket positioning helps operator keep the same tilt of the load during lifting.

³ Includes Lexan front door, top and rear windows.

⁴ Special applications kit (see #3) must be used.



B-1789

Bobcat Company
P.O. Box 6000 • West Fargo, ND 58078
www.bobcat.com

Printed in U.S.A.

An **IR** Ingersoll-Rand business

Kn-20M-605-#B6341205-F

Bobcat Attachments for this model:

- Angle Broom*
- Auger
- Backhoe
- Box Blade
- Brushcat
- Rotary Cutter
- Brush Saw
- Buckets
- Chipper*
- Combination Bucket
- Concrete Mixer*
- Concrete Pump
- Digger
- Dozer Blade*
- Drop Hammer
- Dumping Hopper
- Flail Cutter
- Front Scarifier
- Grader*
- Grapple, Farm (for use with utility fork or bucket)
- Grapple, Industrial
- Grapple, Root
- Hydraulic Breaker⁴
- Landplane
- Landscape Rake
- Mower
- Pallet Fork
- Pallet Fork, Hydraulic
- Planer*
- Rear Stabilizer
- Scarifier
- Scrapper
- Seeder
- Snow Blade
- Snowblower*
- Snow V-blade
- Sod Layer*
- Soil Conditioner*
- Spreader
- Stump Grinder*
- Sweeper
- Three-Point Hitch
- Tiller
- Tilt-Tatch
- Tree Spade*
- Trench Compactor
- Trencher
- Utility Fork
- Vibratory Roller
- Water Kit
- Wheel Saw
- Whisker Push Broom

* Attachment Control Kit required.