



# Bobcat 463...the biggest little loader on the market!

The compact Bobcat® 463 skid-steer loader is the versatile attachment carrier that out-works, out-digs everything in its class.

- 700 lb. Rated Operating Capacity
- 10 GPM Hydraulic Flow
- 22.5 hp Liquid-Cooled Diesel Engine

## Big performance in a small package!

The 463 loader makes compactness a virtue. It goes where bigger machines can't go. It's low in cost. It's easily transportable. Yet it's also dependable, agile, productive, labor-saving, operator-friendly — and is equipped with a cab that offers many of the comforts of a much larger machine!

But most of all, the 463 is versatile. With a choice of nearly 20 hard-working Bobcat attachments, you and your 463 can tackle just about any job with ease and confidence.



**Standard BOB-TACH™ Mounting System Assures Fast, Secure Attachment Changes!**



Turf tires are also available.



### Exclusive Bob-Tach™ System.

For fast, secure attachment changes. Bob-Tach frame (A) moves into attachment flange (B) handle (C) pushes down easily, pressing wedge (D) through frame and attachment hole for solid connection.



### Adjustment Not Needed.

The Bobcat "bow-tie" drive chain design uses pre-stressed, heavy-duty drive chains in two short continuous loops on each side. That means no periodic, time consuming adjustments, plus long life even in the most rugged conditions.



### Bearing Grease?

**Forget It!** Self-lubricating axle bearings never need greasing. The unique hub design offers great seal protection.

### Training

Training kits, available at your dealer's parts department and new operators on the latest skid-steer functions for Bobcat. A Spanish language version is also available. Check with your dealer for more information.

# Hook Up to These Job-Matched Bobcat Attachments



**Angle Broom**  
Sweeps snow, dirt and debris from driveways, loading docks and warehouse floors.



**Auger**  
Drills holes with speed and plumb-line accuracy.



**Snowblower**  
Powerful snow mover. Discharge chute is controlled from operator's seat.



**Mini Scraper**  
Cleans ice and snow off parking lots; scrapes floors; removes tile flooring.



**Backhoe**  
Converts loader into a digging machine. Digging depths up to 5.5 ft.



**Breaker**  
Breaks up concrete and asphalt quickly and effortlessly.



**Tiller**  
Digs and loosens soil; mixes compost and other materials into existing soil.



**Trencher**  
Handles a wide range of jobs, including trenching close to buildings.



**Buckets**  
There's a bucket for every job, from digging to dumping.



**Dumping Hopper**  
Loads quickly and saves time by hauling more material in fewer trips to the dumpsite.



**Utility Blade**  
Use it as both a snow blade or dozer blade. Curved moldboard angles 30 degrees.



**Utility Fork**  
Grabs bulky, hard-to-handle material: loose hay, bedding, manure and bundled items.



**Landplane**  
Removes large clods and rocks, breaks up hard ground, sorts debris from soil.



**Pallet Fork**  
Handles palletized material on farms, construction jobs and industrial sites.



**Utility Grapple**  
Handles loose hay, straw, manure, bales and hard-to-grasp material. Use it with bucket or pallet fork.

**Training Resources.**  
Available through your Bobcat dealer department, let you train current operators and service technicians on safe operation and servicing Bobcat skid-steer loaders. A language version is also available. Check the Bobcat website for more information: [www.bobcat.com](http://www.bobcat.com)



**Serviceability.**  
Bobcat skid-steer loaders feature easy servicing and quick access to components should repairs be needed. Service technicians can get to hydraulic/hydrostatic components quickly by unbolting two nuts and lifting the cab back. The tailgate swings out — allowing fast, easy access to engine components.



**Belt Drive Advantage.**  
The Bobcat belt drive advantage means Bobcat loader engines can be run slower, resulting in a quieter machine that lasts longer and uses less fuel. This system also maximizes pump efficiency and minimizes steering lever effort. Ask about the 3-year belt warranty!



## Specifications

### Performance

**463**

Rated Operating Capacity	700 lb. (318 kg) <sup>1</sup>
Tipping Load	1405 lb. (637 kg)
Hydraulic Pump Capacity	10 GPM (37.8 L/min.)
Travel Speed	6.5 MPH (10.5 km/hr.)
Operating Weight	2708 lb. (1228 kg)

### Dimensions

Length (with bucket)	100.5 in. (2553 mm)
Width (with bucket)	36.0 in. (914 mm)
Height	71.4 in. (1814 mm)
Height to Bucket Pin	94.5 in. (2399 mm)

### Engine

Model	D1005-E
Fuel/Cooling	Diesel/Liquid
Cylinders	3
SAE NET HP/Displacement	22.5/61.1 in. <sup>3</sup> (1.0 L)
Fuel Tank Capacity	6.5 gal. (24.6 L)

### Operation

Steering and Drive	Forward, reverse, travel speed and steering controlled by two hand levers.
Hydraulics	Raise/lower lift arms and dump/rollback bucket controlled by two foot pedals.
Transmission	Hydrostatic, four-wheel drive.

### Standard Features

5.70-12 Standard Tires	Meters/Gauges/ Warning Lights
Bob-Tach	Operator Cab
Bobcat Interlock Control System (BICS™)	Parking Brake
Front & Rear Lights	Rear Window
Front Auxiliary Hydraulics	Seat Bar
High Back Cushion Seat	Seat Belt
Lift Arm Support	Spark Arresting System

### Options/Accessories

Attachment Control Kit	Side Windows Kit
Backup Alarm	Single-Point Lift Kit
Bobcat Heavy-Duty Tires	Skid-Steer Loader Training Kit
Cab Enclosure	Sound Cab <sup>(reduces noise)</sup>
Cab Heater	Special Applications Kit <sup>3</sup>
Catalytic Purifier	Strobe/Rotating Beacon Lights
Horn	Suspension Seat
Hydraulic Bucket Positioning <sup>2</sup>	Top Window
Keyless Start Kit	Turf Tires
Service Safety Training Course	

\*Attachment Control Kit Required.

## Bobcat 463... the loader for tough jobs in tight spots.

The compact Bobcat 463 skid-steer loader is small enough to get in the tight spots, yet tough enough to get you out.

This agile little workhorse is only 6 feet tall and 3 feet wide — the ideal size for scooting through narrow doorways, corridors, aisles, alleys and gates, and for working under low ceilings.

It's the perfect loader whenever the job is too big for a shovel or the space is too small for a larger machine — in backyards, barns, construction sites and demolition areas.

And versatile? You bet. With more than 20 Bobcat attachments to choose from, the 463 is a multi-attachment carrier that's ready to take on just about any job.

Plus — you get to do your work in the comfort and safety of the 463's operator-friendly, FOPS/ROPS-approved cab (Falling Object Protective Structure and Roll-Over Protective Structure). You'll also appreciate the comfortable high-back seat, low noise and easy entry and exit.

The 463 gives you 700 pounds of rated operating capacity and a rugged 22.5 horsepower liquid-cooled diesel engine that powers the hydrostatic 4-wheel drive.

Like all Bobcat loaders, the 463 allows quick, easy access to hydrostatic, hydraulic and engine systems, thanks to the swing-out tailgate and tip-up cab.

All this, and an excellent warranty, too. Check out the compact 463 skid-steer loader at your Bobcat dealer's showroom. It's the loader that's small in size, small in price, but big in value, comfort, performance and versatility!

**700 LB.**  
Rated Operating Capacity

**10 GPM**  
Hydraulic Flow

**22.5 HP**  
Liquid-Cooled Diesel Engine

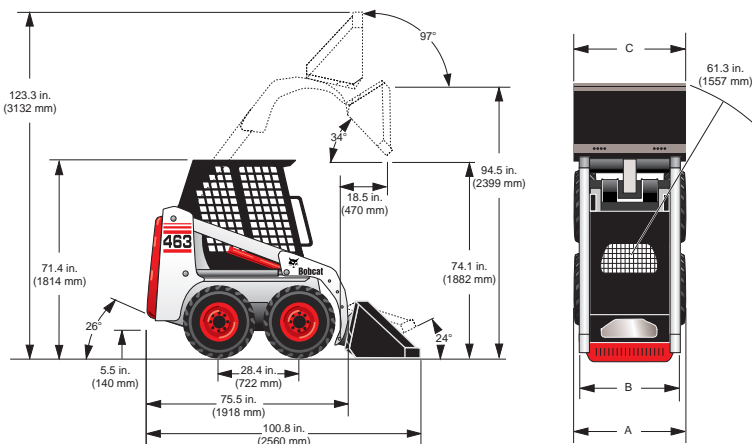

NOTE — Where applicable, dimensions are in accordance with Society of Automotive Engineers (SAE) and ISO standards. Specifications and design are subject to change without notice. Pictures of Bobcat loaders may show other than standard equipment. All dimensions are given for loader equipped with standard tires. All dimensions are shown in inches. Respective metric dimensions are enclosed by parentheses. Bobcat Company complies with the requirements of ISO 9001 as registered with BSI.

<sup>1</sup>Operating capacity rated with standard digging bucket according to SAE standard J818. OPERATING CAPACITY TO EQUAL NO MORE THAN ONE HALF THE TIPPING LOAD.

<sup>2</sup>Bucket positioning helps operator keep the same tilt of the load during lifting.

<sup>3</sup>Includes Lexan front door, top and rear windows.

<sup>4</sup>Special application kit (see #3) must be used.

A - 5.70 x 12 Tires - 35.4 in. (900 mm)  
23 x 8.50 - 12 Tires - 43.3 in. (1100 mm)

B - 5.70 x 12 Tires - 29.4 in. (747 mm)  
23 x 8.50 - 12 Tires - 34.8 in. (884 mm)

C - 36 in. Bucket Width - 36.0 in. (914 mm)  
44 in. Bucket Width - 44.5 in. (1130 mm)



B-1734

Bobcat Company  
P.O. Box 6000 • West Fargo, ND 58078  
www.bobcat.com

Printed in U.S.A.

An **IR** Ingersoll-Rand business

Kn-10M-905-#B6346205-F

## Bobcat Attachments for this model:

- Angle Broom
- Auger
- Backhoe
- Bale Fork
- Boring Unit
- Breaker<sup>4</sup>
- Buckets
- Combination Bucket
- Digger
- Dumping Hopper
- Grapple, Utility (for use with utility fork or bucket)
- Landplane
- Mini Scraper
- Pallet Fork
- Snowblower\*
- Snow V-Blade\*
- Soil Conditioner
- Stump Grinder
- Sweeper
- Tiller
- Trencher
- Utility Blade
- Utility Fork

\*Attachment Control Kit required.